



TRI-TRONICS®

Smart Photoelectric Solutions Since 1954



XP10 – Extremely High Speed Sensor



800-237-0946 ttco.com 813-886-4000



Extremely High Speed (10 μ s) Photoelectric Sensor

The SMARTEYE[®] X-PRO XP10 is the highest speed (10 μ s) dual-function sensor in the world. This dual-function sensor is designed to be a precision registration mark sensor with 5 μ s repeatability, and a standard photoelectric sensor for any high speed application, in one package.

Mark Mode allows the user quick and easy set-up for detection of registration marks by performing an AUTOSET with the background in view. When in Mark Mode, the sensor will automatically configure to give an output on the mark.

Standard Mode allows the user independent control of the AUTOSET mode, (Light State or Dark State), and output, (Light ON or Dark ON). Standard Mode provides the greatest flexibility for general purpose applications.

Five Memory Locations are available to be used in either Mark Mode or Standard Mode when the Enable option is selected. These Memory locations can store all options and AUTOSET settings for up to five different application requirements. This Memory feature allows fast changeover when running several different types of materials on the same machine. Additionally, when the Enable option is selected, the sensor has the ability to be programmed by a PLC or other device via the Remote AUTOSET input wire. You can access any option, Memory location, or AUTOSET routine through this uniquely designed input feature.

No other sensor in the world gives you these high performance features packaged together in one compact design. The SMARTEYE[®] X-PRO XP10 photoelectric sensor from Tri-Tronics is the most comprehensive sensor available in its class.



Features

- 10 μ s Response Time
- 5 μ s Repeatability
- Dual-Function Sensor
 - Mark Mode – For Registration
 - Normal Mode – Object Sensing
- 5 Memory Locations
- PLC and External Programming Through the Remote Input Line
- Connector or Cabled Version
- Available in White, Red and Infrared LED
- Patents No. 5,621,205 and No. 6,950,778
- AUTOSET - One-Touch Setup
- 10-LED Dual-Function Bar Graph

Benefits

- Increase Edge Accuracy at All Speeds
- Virtually Eliminate Setup Time
- Save 100% Registration Waste Cost
- Eliminate Compensation Software Requirement
- Repeatable Leading Edge or Trailing Edge Accuracy Consistently at 5 μ s
- Increase Throughput Capacity
- Eliminate Machine Speed Constraint

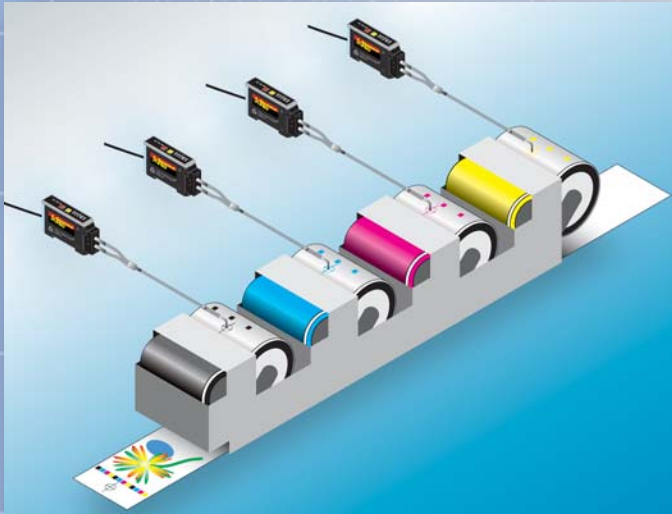

High Speed Offset Printing

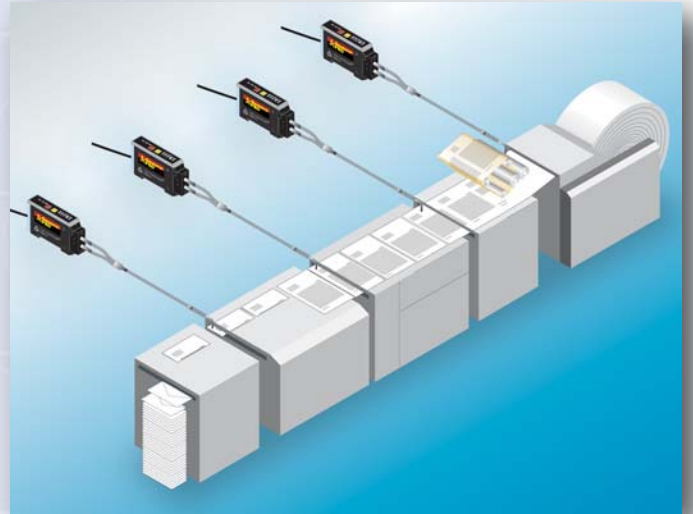

High Speed Paper Converting

When Timing is Everything!

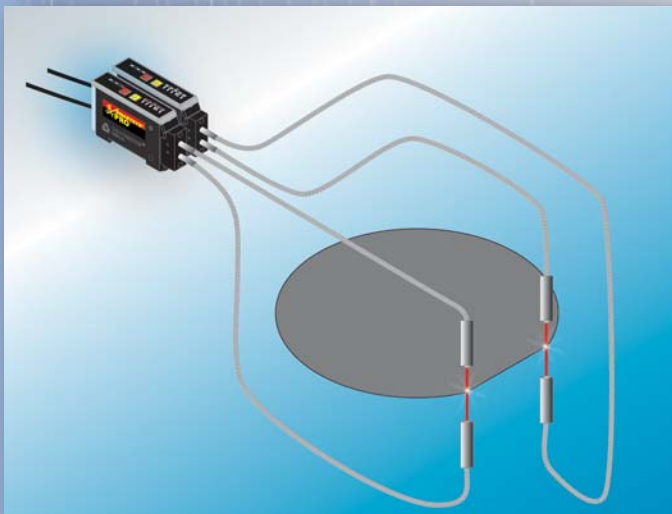

High Speed Edge Detecting

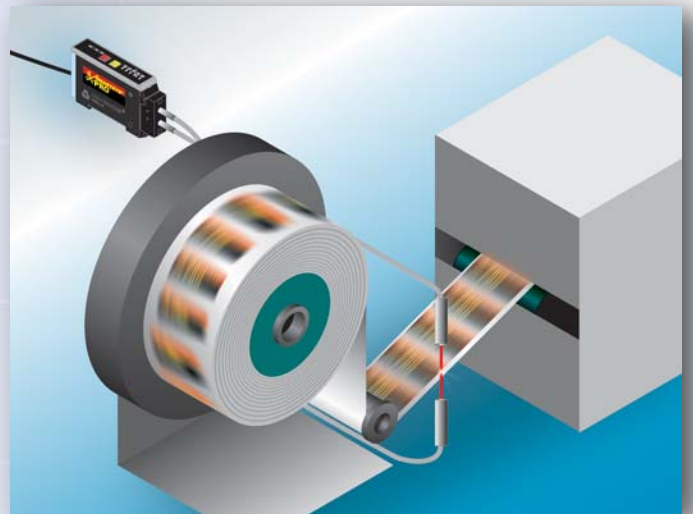

High Speed Label Rewinding

Features

AGS™ AUTOMATIC GAIN SELECT

This unique feature provides automatic digital selection of amplifier gain based upon your sensing requirements.

AUTOSET ADJUSTMENT

The AUTOSET adjustment routine only requires the push of one button, one time! Oftentimes, in dynamic operating conditions, all you have to do is push the button for a perfect setting. This is dependent upon at least a 4:1 duty cycle ratio.

AUTOSET/ REMOTE PROGRAMMING (Patent No. 6,950,778)

Remotely AUTOSET or program the sensor's multiple options by applying a sequential momentary contact closure from the AUTOSET input wire to negative as shown in the wiring diagram. The remote AUTOSET command will duplicate the last manual AUTOSET.

EDR® (Patent No. 5,621,205)

Another unique feature is the digitally controlled EDR (Enhanced Dynamic Range) circuit. It prevents dark state saturation and expands the operating range without reducing amplifier gain.

10 LED DUAL-FUNCTION BAR GRAPH

Contrast Indicator™ – Provides “at-a-glance” performance data.

Status Indicator – Displays status of selectable options:

Lock – When this option is enabled the sensor becomes tamperproof. Note: The remote AUTOSET and programming are not effected by the Lock option.

Mark – When this feature is enabled, the sensor buttons function like a MARK-EYE® PRO: Push and hold yellow button for light background and red button for dark background.

Pulse Stretcher (PS) – When the “OFF” delay pulse stretcher is enabled, the output duration is extended by 10 or 20 milliseconds (not additive).

Enabling the Timer allows ample time for the controller to respond. The time durations of the gap between marks must be less than the selected delay.

Enable – This option provides access to MEM-1 thru MEM-5 locations and enables remote programming.

HIGH SPEED

10µs response time when responding to light or dark state.

5µs repeatability.

CONNECTIONS

Built-in 5-pin M12 connector, or 6' Cable.

MOUNTING OPTIONS

Built-in DIN rail “Snap-On” design, through hole, or bracket mount.

DUAL FUNCTION BAR GRAPH

Primary function: Contrast Indicator
Secondary function: Option Status Indicator of 10 selectable options

#10 LOCK

Tamperproof Operation

#9 MARK

When illuminated – “ON” = Mark Mode
When not illuminated – “OFF” = Standard Mode

#8, 7 PULSE STRETCHER (PS)

10 or 20 Millisecond Pulse Stretcher
“OFF” Delay

#6 ENABLE

Illuminates when advanced features are enabled...MEM 1 - MEM 5 and remote programming

#5 – #1 MEMORY (MEM)

Illuminates to Indicate Active Memory

OPTION STATUS INDICATOR

Illuminates when in Option Status Mode

OUTPUT INDICATOR

Illuminates when Output is “ON”

MARK MODE INDICATOR

Illuminates when Mark Mode is enabled

LARGE HIGH VISIBILITY OUTPUT INDICATOR

Illuminates when Output is “ON”

10 INTERCHANGEABLE OPTICAL BLOCKS

1. O4 (Wide Beam Proximity)
2. O5 (Long Range Proximity)
3. R4 (Retroreflective)
4. R5 (Polarized Retroreflective)
5. V4 (Convergent, 1" Axis)
6. V4A (Convergent, 1" Axis, Apertured)
7. V6 (Convergent, 1.5" Axis)
8. V8 (Convergent, 0.5" Axis)
9. F4 (Glass Fiberoptic Light Guides)
10. F5 (Plastic Fiberoptic Light Guides)

YELLOW PUSHBUTTON – 4 Functions

1. Manual “UP” Adjustment
2. Options Select & AUTOSET Programming
3. Toggle Selected Option To Opposite State And Return To Normal Operation
4. When holding AUTOSET Button, tap to alter AUTOSET mode... Light State/Dark State

RED PUSHBUTTON – 4 Functions

1. Manual “DOWN” Adjustment
2. Options Select & AUTOSET Programming
3. When in Option Status Mode, tap to desired function to be altered
4. When holding AUTOSET Button, tap to alter AUTOSET mode... Light State/Dark State

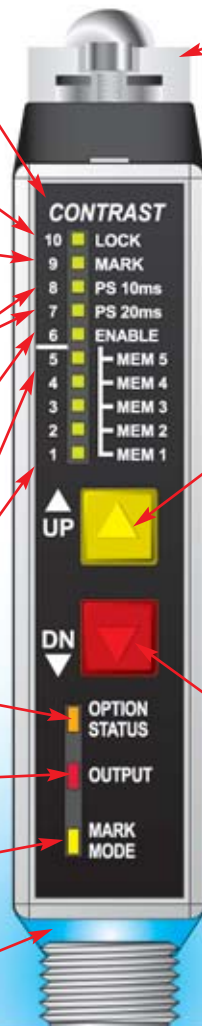

Special Features

REMOTE PROGRAMMING

The Remote Programming feature of the SMARTEYE® X-PRO XP10 allows the customer to configure, AUTOSET, and tweak the sensor using a PLC pulse-train, HMI, MMI, NPN transistor output, or momentary pushbutton switch to 0 VDC/ground. This provides the customer with control over every aspect of the sensor configuration without having to physically touch the sensor. If you have several sensors on your machine; have sensors buried deep within the mechanical structure of the machine; or have your sensors in safe areas behind interlocks... you can easily access these sensors remotely to perform a "digital changeover" due to this unique, special feature.



MMI - Man Machine Interface



HMI - Human Machine Interface



Momentary Push Button

Ex. Selection of MEM 1

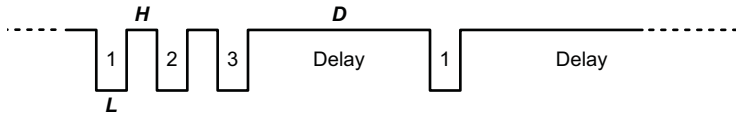

Each pulse (L) is low for 40ms to 400ms. The idle time (H) between pulses is 40ms to 400ms. The delay (D) between sets of pulses is .75 seconds to 5 seconds.

FIVE MEMORY LOCATIONS

There are Five Memory locations available to store various configurations of the sensor for particular applications. For instance, if you have 5 different web materials...the background colors are different, the mark colors are different, and the marks are different sizes...you would need to perform a different AUTOSET for each background, and you might need to add a Pulse Stretcher timer for the different sized marks. The SMARTEYE® X-PRO XP10 sensor allows you to store and recall that information so the setup time is eliminated completely, reducing down-time and change-over complications when running different materials. This feature is also a benefit with any other application with changing conditions;

different sized bottles, different colored labels, varying background materials, varying product textures, etc.

Packaging Five Memory locations together with the unique Remote Programming feature above makes the SMARTEYE® X-PRO XP10 sensor the fastest sensor in the world for "rapid digital changeover", as well as for speed and accuracy.

Ex. Five Registration Marks

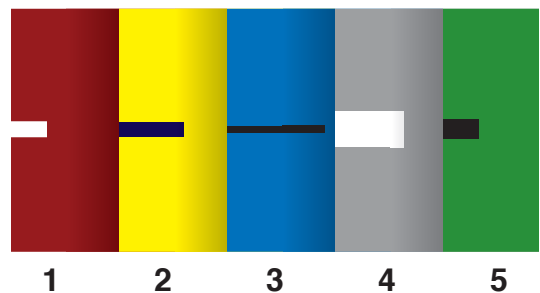

(Mark Samples)



How to Specify



1. Select Sensor Model based on LED Light Source required:

XP10W = White
 XP10R = Red
 XP10I = Infrared

2. Select Connection required:

Blank = Cable
 C = Connector

3. Select Optical Block:

F4 Glass Fiber Optic
 F5 Plastic Fiber Optic
 V4 Convergent Lens, 1.0" Focal Point
 V4A Convergent Lens, 1.0" Focal Point
 V6 Convergent Lens, 1.5" Focal Point
 V8 Convergent Lens, 0.5" Focal Point
 R4 Retroreflective Lens
 R5 Polarized Retroreflective Lens
 O4 Wide Beam Proximity Lens
 O5 Long Range Proximity Lens

Example:

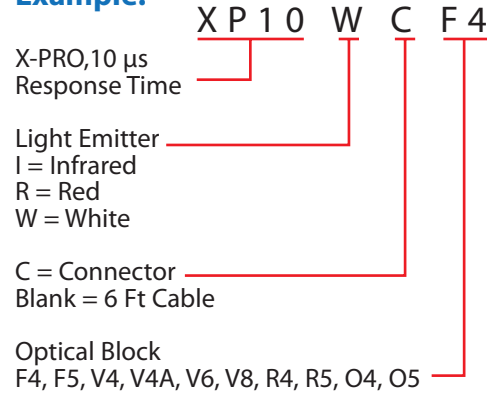

Sensing Range Guidelines

Convergent / Proximity / Retroreflective				Glass Fiberoptics				Plastic Fibers				
Optical Blocks	Retroreflective			Optical Blocks	IR	RED	WHITE	Optical Blocks	.04" Diameter		.02" Diameter	
	IR	RED	WHITE						RED	WHITE	RED	WHITE
V4, V4A	1 in.	1 in.	1 in.	Opposed Mode				Opposed Mode				
V6	1.5 in.	1.5 in.	1.5 in.	F4	6 in.	6 in.	11 in.	F5	4 in.	4 in.	1 in.	1 in.
V8	0.5 in.	0.5 in.	0.5 in.	F4 w/lens	6 ft.	6 ft.	6 ft.	F5 w/lens	4 ft.	3 ft.	N/A	N/A
O4	4 in.	3.75 in.	5 in.	Proximity Mode				Proximity Mode				
O5	30 in.	26 in.	18 in.	F4	2.0 in.	2.0 in.	1.75 in.	F5 w/right angle lens	3 ft.	1 ft.	N/A	N/A
R4	15 ft.	12 ft.	8 ft.	F4 w/lens	6 in.	6 in.	6 in.	F5	1 in.	1 in.	0.25 in.	0.25 in.
R5	N/A	3 ft.	1 ft.	No Prox on craft paper				F5 w/lens	1.5 in.	1.5 in.	N/A	N/A
R4	4 ft.	6 ft.	4 ft.	Note: Proximity tests utilized a 90% reflective white target. Retroreflective test utilized a 3" diameter round reflector, Model AR3.				Note: Proximity tests utilized a .125" diameter fiber bundle.				

Hardware & Accessories

• Micro Cable Selection Guide, 5-wire, M12



GSEC-6
 6' (1.8 m) Shielded cable



GSEC-15
 15' (4.6 m) Shielded cable



GSEC-25
 25' (7.62 m) Shielded cable

GSEC-2MU
 6.5' (2.0 m) Low-cost, unshielded

GSEC-5MU
 16.4' (5.0 m) Low-cost, unshielded

GRSEC-6
 6' (1.8 m) Right angle shielded cable

GRSEC-15
 15' (4.6 m) Right angle shielded cable

GRSEC-25
 25' (7.62 m) Right angle shielded cable

GX-25
 25' (7.62 m) extension cable



FMB-1 (8.4 mm diam.)
 Standard Fiberoptic Mounting Bracket



SEB-3
 Stainless "L" Bracket



FMB-2 (5.1 mm diam.)
FMB-3 (3.1 mm diam.)
 Miniature Glass or Plastic Fiberoptic Mounting Brackets



LK-4
 Lens Kit
 (See Optical Blocks Accessories for contents)

Specifications

SUPPLY VOLTAGE

- 12 to 24 VDC
- Polarity Protected

CURRENT REQUIREMENTS

- 45mA (exclusive of load)

OUTPUT TRANSISTORS

- (1) NPN and (1) PNP sensor output transistors
- Outputs sink or source up to 150mA (current limit)
- All outputs are continuously short circuit protected

REMOTE AUTOSET INPUT

- Opto-isolated momentary sinking input (10mA)

RESPONSE TIME

- Light/Dark = 10 μ s
- Repeatability = 5 μ s

LED LIGHT SOURCE

- Infrared = 880 nm, Red = 660 nm, White = Broadband Color Spectrum

PUSHBUTTON CONTROL

- AUTOSET
- Manual Adjustments
- Set status of 10 options: 10) Lock, 9) Mark, 8) PS 10ms, 7) PS 20ms, 6) Enable, 5-1) Five Memory Locations

HYSTERESIS

- Set for high resolution – less than one bar on the contrast indicator

LIGHT IMMUNITY

- Responds to sensor's pulsed modulated light source – immune to most ambient light including indirect sunlight

DIAGNOSTIC INDICATORS

- 10-LED dual-function bar graph operates in one of two modes:
 1. Contrast Indicator – Displays scaled reading of sensor's response to contrasting light levels (light to dark)

2. Status Indicator – Displays status of 10 selectable options
- Red LED output indicator – Illuminates when the sensor's output transistors are "ON"

NOTE: If Output LED flashes, a short circuit condition exists
 - Amber LED – Illuminates when in the Option Status Mode
 - Yellow LED – Illuminates when Mark Mode feature is activated
 - Blue LED output indicator - Illuminates when output is "ON".

AMBIENT TEMPERATURE

- -40°C to 70°C (-40°F to 158°F)

RUGGED CONSTRUCTION

- Chemical resistant, high impact polycarbonate housing
- Waterproof ratings: NEMA 4X, 6P and IP67
- Conforms to heavy industry grade CE requirements

Patents No. 5,621,205 and No. 6,950,778



RoHS Compliant

Product subject to change without notice.

Connections and Dimensions

SMARTEYE® X-PRO XP10

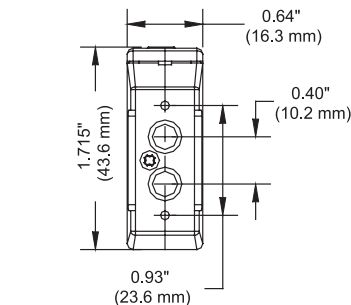

Choice of Built-In 6' Shielded Cable or 5-pin, M12 Connector for Use With Optional Cables

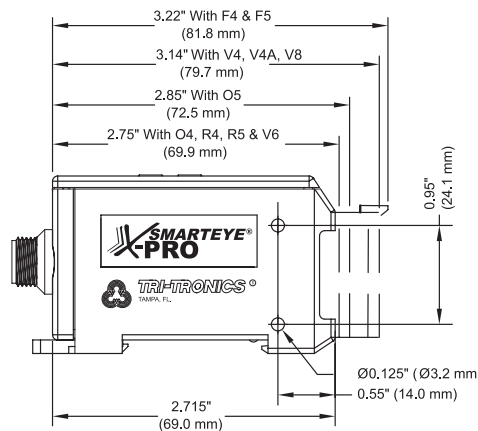
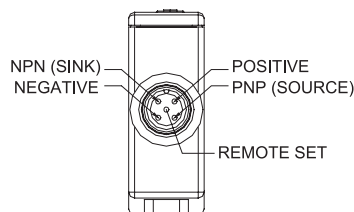

*Sensors with connectors

P/N SEB-3
Optional Mounting
Bracket With Hardware

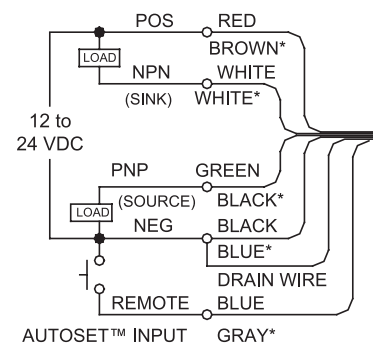
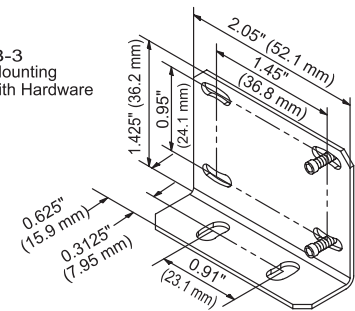



TRI-TRONICS®

Smart Photoelectric Solutions Since 1954



P.O. BOX 25135 • TAMPA, FL 33622-5135

813-886-4000 • 800-237-0946

FAX: 813-884-8818 • 800-375-8861

ttco.com • info@ttco.com

004-0147